



**BUSCH**<sup>®</sup>  
SYSTEMS



# Revive Series

*Spaces Re-Imagined, Safely*

Product Data Sheet | Version 1.0

Busch Systems International Inc.  
81 Rawson Avenue, Barrie ON., Canada  
1.800.565.9931  
buschsystems.com



*View the Revive Series Online!*

Part of the  
**Prevent+**<sup>™</sup>  
collection





# Spaces Re-Imagined, Safely

The Revive offers a simple, functional, and aesthetically pleasing solution for dispensing your hygiene products such as anti-bacterial wipes. Simply fill the dispenser with your desired material and place it in high traffic areas or where guests & employees need them most. The unit is exceptionally durable and constructed with 100% post-consumer recycled plastic lumber, that promotes your commitment to a circular economy while maintaining a visually pleasing environment.



105437



105391

## BODY SPECIFICATIONS

Below are the available station options for the Revive Series. With this measurement guide you will ensure the Revive Series container is the right size to fit your space. The measurement guide is the essence of various standard measuring methods. The Revive Series recycled plastic lumber containers are available in a Single configuration. Talk to your dedicated Busch Systems® sales representative for more information on how to choose the right size container for your space.

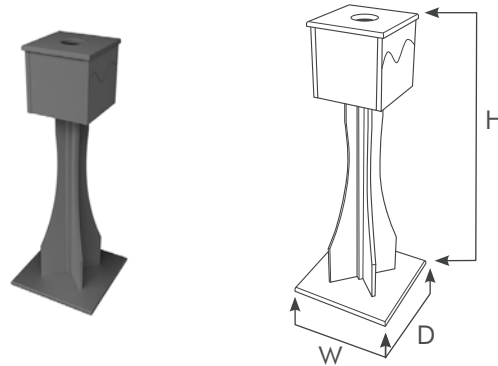

Body Shape	Height	Width	Depth	Weight
Standard	39.88"H (1013mm)	15"W (381mm)	16"D (406.4mm)	20lbs (9.1kg)

## STOCK PANEL COLORS

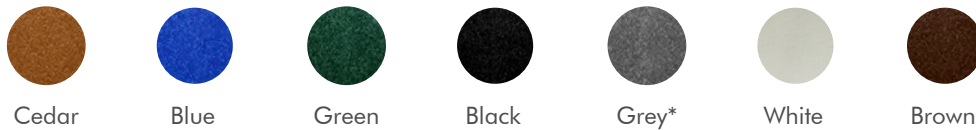

## STOCK POST COLORS



\*Assembled and ready to ship in small quantities.

## BOX SPECIFICATIONS

Below are the inside measurements for the Revive Series box. Using this measurement guide will help you source the right size wipe to fit inside the Revive Series container.

Box	Height	Width	Depth
Inside Box	8"H (203.2mm)	8"W (203.2mm)	8"D (203.2mm)

## MATERIAL & CONSTRUCTION DETAILS

Not all recycling, waste or PPE receptacles are created equal. Our company policy is never to compromise on our workmanship or the quality material standards we've set. We only recommend and use quality first grade materials on our containers, and source these from OEM's at highly-competitive prices. Being a manufacturer that buys at high-quantities gives significant buying power with companies which in turn saves you money.

The design process, materials used, finishes and manufacturing standards all affect the final product. Every decision is vital to getting the most value for your investment. You deserve recycling, waste and PPE containers that meet your demands for quality and durability and will enhance your working environment for years to come.

Busch Systems® Recycled Plastic Lumber products are made from 100% maximum-strength, post consumer HDPE (most often recycled milk jugs!). The Revive Series stations do not absorb moisture, are resistant to rotting, heat & mold and are developed using the highest-quality, rust-resistant hinges, fasteners & screws. Commercial-grade resins and UV resistors are added to the recycled lumber during the manufacturing process to prevent fading due to sun and harsh weather exposure.

The LEED® green building certification program is the nationally accepted benchmark for the design, construction and operation of green buildings. Busch Systems® recycled plastic lumber receptacles are made of 100% pure post-consumer HDPE (not including hardware) and may contribute to your LEED® goals under MR 4.1 and MR 4.2.

Component	Material(s)	Construction
Body	Recycled Plastic Lumber	<ul style="list-style-type: none"> <li>Made of 100% pure post-consumer HDPE (not including hardware)</li> </ul>

## ENVIRONMENTAL CONSIDERATIONS

- Revive Receptacles are composed primarily of natural materials local to manufacturing
- All Revive Receptacles use a low energy, resource efficient manufacturing and curing process
- All Revive receptacle components disassemble at end of life and are fully recyclable
- Low maintenance and extremely long service life
- Manufactured in North America

Configurations	Post-Industrial Recycled Content	Post-Consumer Recycled Content	Total Recycled Content	3rd Party Certifications
Revive	Contact us	Contact us	Contact us	-

Busch Systems® is dedicated to environmental responsibility. We maintain an Environmental Management System and are continually working to improve our impact through efficiency, material selection, vendor education, employee involvement, and an unwavering commitment to being a B-Corporation®. If you would like additional information on our product development process or if you don't see the information you need for your project on this page, please contact our Sustainability Team at [sustainability@buschsystems.com](mailto:sustainability@buschsystems.com).

## LEAD TIME

Our standard lead times on the Purify Series are 2-3 weeks. Larger orders may require 6-8 weeks to complete. Please contact us to discuss your specific timing requirements.

## PRICING AND ORDERING

Please contact us at **800.565.9931** or [sales@buschsystems.com](mailto:sales@buschsystems.com). At Busch Systems®, we design, manufacture and sell our products directly to you. Our sales team is available to assist you with questions about our products, requests for quotes, and orders. Vertical Managers are located across North America to assist with the front-end specification and quoting process, and our in-house Project Sales Coordinators follow your project through from the time you place an order to shipment.

## TO ORDER PLEASE SPECIFY

Quantity, color & series model. Talk to your dedicated Busch Systems® sales representative for more information. If you do not have a dedicated Sales Representative please contact us via our website at [buschsystems.com/contact-us/](https://buschsystems.com/contact-us/)

## INSTALLATION

Busch Systems® Revive Series containers are hassle-free when it comes to installation. Each container comes fully-assembled and individually boxed using high-density cardboard with high-recycled content to ensure safe and environmentally friendly transport.

To install your Revive Series containers:

1. Remove unit from pallet and place in desired location
2. (Optional) Apply your chosen labels
3. Open lid to add box of wipes (*Please Note: Wipes are not included in the purchase of Revive units*)

## CARE & MAINTENANCE

Advantages of Busch Systems® Recycled Plastic Lumber receptacles include:

- Made from 100% maximum-strength, post consumer HDPE (most often recycled milk jugs!)
- Highly-durable material and is able to withstand physical stress to a greater degree than wood.
- Minor dings and scratches are much less likely to bend your containers out of shape or leave the finished scratched.
- Do not absorb moisture, are resistant to rotting, heat & mold and are developed using the highest-quality, rust-resistant hinges, fasteners & screws.
- Commercial-grade resins and UV resistors are added to the recycled lumber during the manufacturing process to prevent fading due to sun and harsh weather exposure.

Their appearance and lifespan will be greatly affected by their care. The frequency of cleaning required depends on the environment in which the containers are used. Outdoor containers will be subject to different environmental conditions than indoor units, i.e. sun, rain, wind, pollution, winter temperatures, and salt/sea air.

To avoid the accumulation of dirt and grime on your Busch Systems® products, and help prevent corrosion, we recommend that a mild detergent be used (not an abrasive), such as a pH-neutral liquid (hand dishwashing or hand car washing soaps, for example) diluted in warm water. Rinse well with clean water. Any dirt adhering to the powder coating should be removed. In order to remove deposits such as salt or dust, use a soft brush (non-abrasive). If this is not sufficient to remove stubborn soiling, the following products have been tested for use:

*Note: Always test soaps/cleaners on a hidden and/or small area beforehand*

- Ajax Cream
- Liquid Gumption
- Cutting compound ('T. Cut')
- Flash (in water)
- Ajax Liquid (in water)

If solvents are absolutely needed to remove marks, a soft cloth dampened with white spirit may be used.

## GENERAL CARE

- Clean with a mild detergent and damp sponge or cloth
- For tougher cleaning purposes, Lysol, TSP or Spray Nine may be used
- To remove permanent marker on melamine, use a small amount of Lacquer Thinner or Acetone on a cotton rag

## THINGS TO AVOID

- Cleaners with chloride or bleach
- Abrasive detergents
- Trapped moisture between product and equipment such as rubber mats
- Strong Solvents
- Steel wool or Scouring pads

*Contact Us Today for a Quote on Your Revive Station!*



**BUSCH**<sup>®</sup>  
SYSTEMS

Certified



Corporation